



www.sourcetecindustries.com

*The future is clean air ... the future is **Sourcetec**[®]*

**Sourcetec Self-Cleaning Mobile
Filter Unit SV-11000**

Description

The Sourcetek SV-1100 Filter Unit can be utilized as a stationary or portable unit. It's a compact dust collector for use in doors where there are space restraints which would not otherwise allow for a full size collector.

Usage

The unit can be used for the capture of:

- Welding Smoke
- Grinding Dust
- Dry Textile Fibers and
- Flour Dust

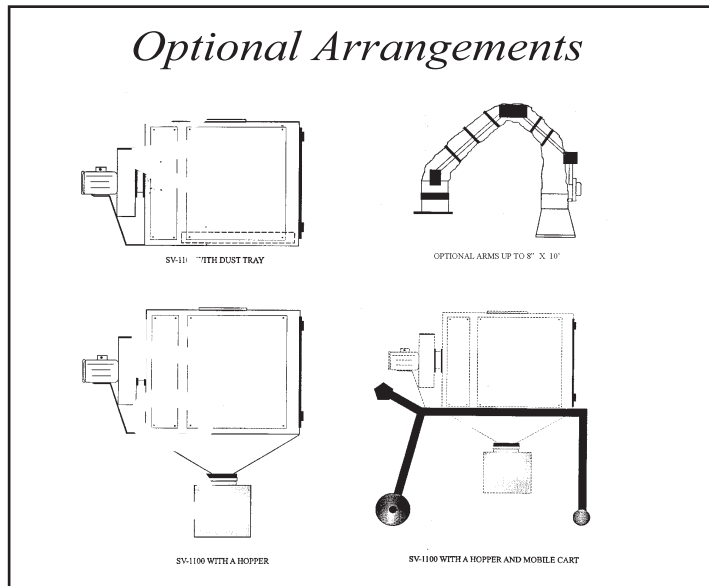
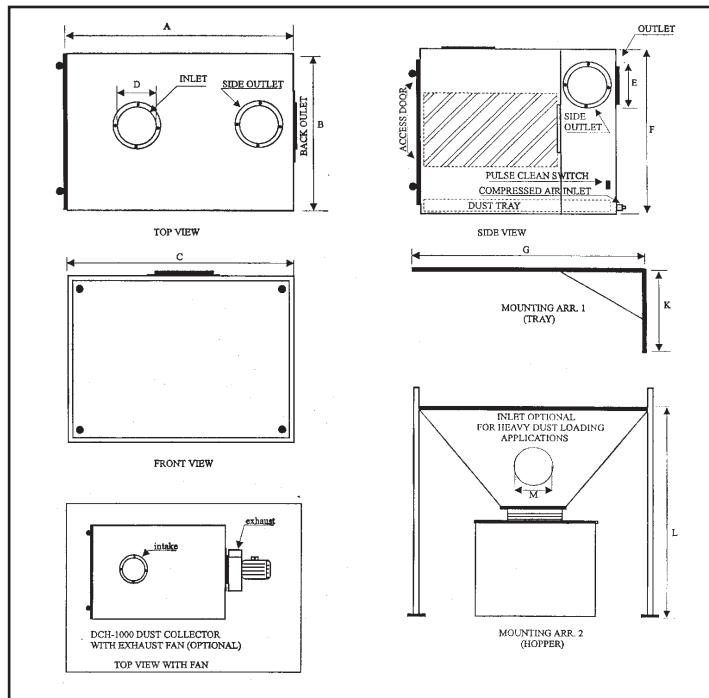

Features

- 13" Wheel
- 3HP Motor
- 1100 CFM @ 2" S.P.
- 208/3/60
- 99.997% Efficient Filter Cartridge at 1 Micron
- Choice of Dust Tray or Hopper
- Pulse Clean Switch
- Standard Timer
- Compressed Air Inlet

Options

- Self cleaning mechanism
- Local switch on hood to turn unit ON/OFF
- Light package on hood, with screen
- Explosion proof motor with special coating
- 8'0" or 10'0" external support arms
- Other voltages
- Outlet location
- Inlet location
- Blower Mounting Options

Distributed by:

The future is clean air ... the future is Sourcetek®

Mississauga, Ontario, Canada
Tel: (905) 678-9333 Fax: (905) 678-7133
Holland, Ohio, USA 1-800-784-2383
www.sourcetekindustries.com
E-mail: sales@sourcetekindustries.com